

KT-BPLED-SM-22-KIT /G2

SURFACE MOUNTING KIT

DESCRIPTION

Surface mount kit for 2x2 LED back-lit panel lights. White finish.

PRODUCT FEATURES

Mounting hardware included.

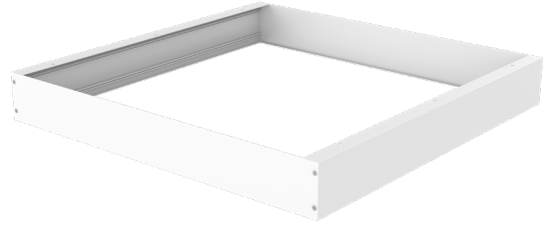

PRODUCT DIMENSIONS

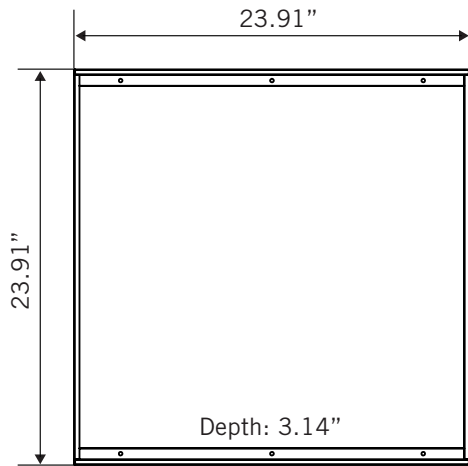

ORDERING INFORMATION

CATALOG NUMBER	CARTON QTY.	EASY CODE	UPC
KT-BPLED-SM-22-KIT /G2	1	GWQ-17	843654134536

CATALOG NUMBER BREAKDOWN

KT-BPLED-SM-22-KIT /G2

1 2 3 4 5 6

- 1 Keystone Technologies
- 2 Backlit Panel Light LED Fixture
- 3 Surface Mount
- 4 2' x 2' Size
- 5 Kit
- 5 2nd Generation